









Inert gas extinguishing technology

Pipe coupling

Fittings "PT" with pressure test upstream piping - 200 bar / 300 bar

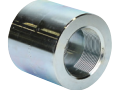
Approvals
without approval

Designation	DN	Thread	Part no.	Weight kg (lbs)
 Cap PT	50	Rc 2	886184	2.1 (4.6)
	65	Rc 2.1/2	886185	3.2 (7.1)
 Reducing nipple PT	65 / 50	Rc 2.1/2 x 2	886210	0.7 (1.5)
 Elbow PT	50	Rc 2	886182	6.3 (13.9)
	65	Rc 2.1/2	886183	9.7 (21.4)
 Tee - piece PT	50	Rc 2	886180	8.1 (17.9)
	65	Rc 2.1/2	886181	12.4 (27.3)
 Socket PT	50	Rc 2	886191	2.9 (6.4)
	65	Rc 2.1/2	886192	3.8 (8.4)
 Hex. nipple PT	50	Rc 2	886189	1.0 (2.2)
	65	Rc 2.1/2	886190	1.8 (4.0)
 Coupling HD	50	Rc 2	886187	3.4 (7.5)
	65	Rc 2.1/2	886188	8.0 (17.6)

Technical data

Working pressure6000 psi = 413,7 bar
Coupling HD = 365 bar (5293 psi)
 Finishgalvanized
 Materialacc. to ASTM A105
Coupling HD acc. to EN 10025-2 - S355J2
 Threadacc. to ISO 7/1 - Rc, cone
 Dimensionsacc. to ANSI B16.11
 Markingmanufacture's sign, dimension,
batch number, pressure stage, material and test mark "PT"

Application

Ar / N₂ / IG-55 / IG-541 high pressure systems 200 bar and 300 bar in application of the procedure specification MXV 044 "Druckprüfungen an Speziallöschanlagen".

SAP designation

e.g. part no. 886184: Cap 6000psi Rc 2"-St-PT

Maintenance

maintenance-free

Spare parts

O-ring coupling HD50, part no. 886412
 O-ring coupling HD65, part no. 886413

Not included in delivery

Hooked wrench for coupling HD50 ...886283, see system accessories
 Hooked wrench for coupling HD65 ...886284, see system accessories



Inert gas extinguishing technology

Pipe coupling

Fittings "PT" with pressure test upstream piping - 200 bar / 300 bar

Dimension drawing

Dimensions in mm (inch)

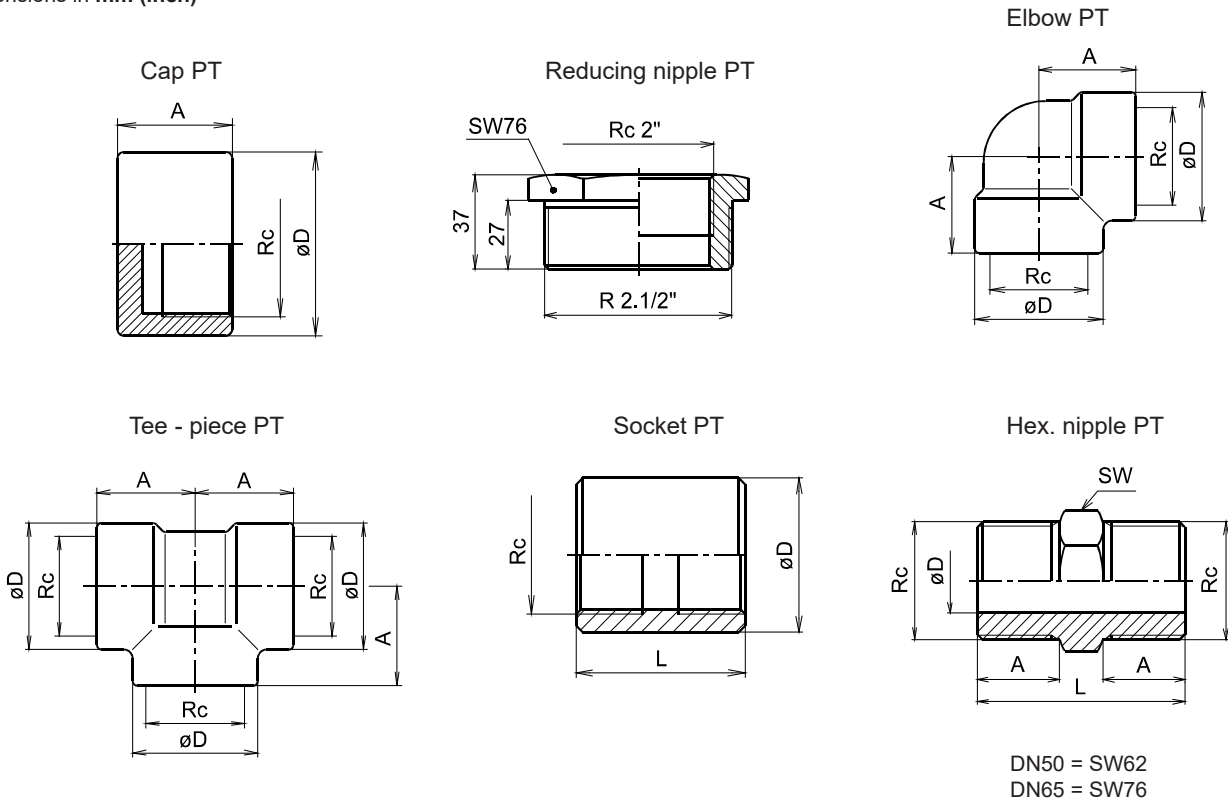

DN50 = SW62
DN65 = SW76

Designation	DN	Thread	A	ød	L
Cap PT	50	Rc 2	51 (2.01)	92 (3.62)	-
	65	Rc 2.1/2	64 (2.52)	108 (4.25)	-
Reducing nipple PT	65 / 50	Rc 2.1/2 x 2	-	-	-
Elbow PT	50	Rc 2	83 (3.27)	102 (4.02)	-
	65	Rc 2.1/2	95 (3.74)	121 (4.76)	-
Tee - piece PT	50	Rc 2	83 (3.27)	102 (4.02)	-
	65	Rc 2.1/2	95 (3.74)	121 (4.76)	-
Socket PT	50	Rc 2	-	92 (3.62)	86 (3.39)
	65	Rc 2.1/2	-	108 (4.25)	92 (3.62)
Hex. nipple PT	50	Rc 2	27 (1.06)	39 (1.54)	71 (2.80)
	65	Rc 2.1/2	37 (1.46)	51 (2.01)	94 (3.70)
Coupling HD	50	Rc 2	75 (2.95)	105 (4.13)	106 (4.17)
	65	Rc 2.1/2	85 (3.35)	140 (5.51)	129 (5.08)

211-322_002 / A100_2017 en
The contents of this publication are subject to modifications without notice. All rights reserved.